

ECSE 2010
Electric Circuits
Exam 3
Spring 2005

Name _____

Section Number (please circle one)

1	2	3
MTR	MWR	MTR
10-12	4-6	2-4

Problem No.	Pts.	Score
1	20pts	
2	30pts	
3	20pts	
4	20pts	
5	20pts	
Total	100pts	

Please Note:

- * Place all your answers in the spaces provided.
- * You MUST show ALL your work or thoroughly describe your solution process to receive any credit.

Problem 1 (20pts)

Name _____

a.) The switch is open for a long time before closing at $t = .5\text{sec}$ in the circuit shown below. Find $V_{\text{out}}(s)$ for $t \geq .5\text{sec}$ and sketch $V_{\text{out}}(t)$ for $t \geq 0$. (10pts)

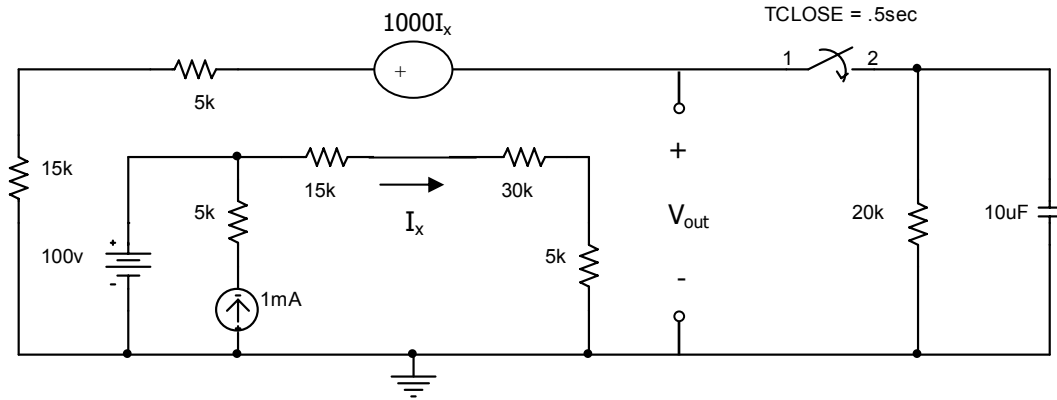

$V_{\text{out}}(s)$	
---------------------	--



Problem 1 (cont)

Name _____

b.) Find $V_{out}(t)$ for $t \geq .5\text{sec}$ given the circuit shown below, showing all pertinent values. (10pts)

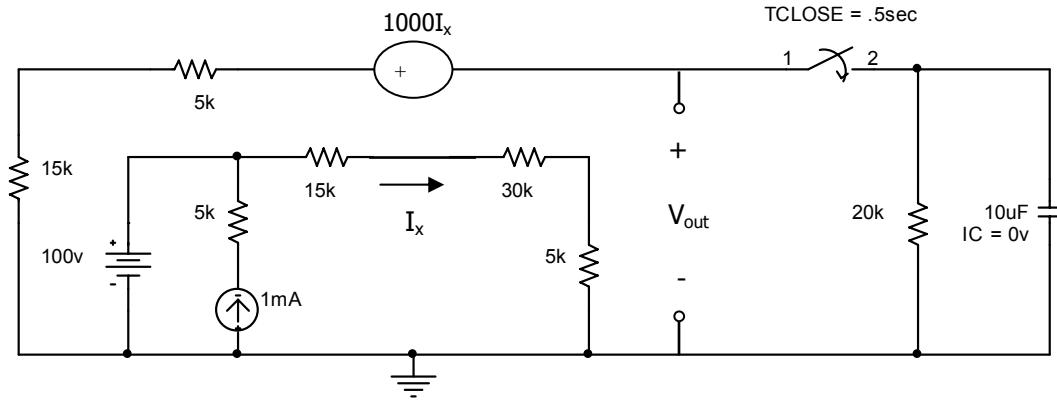

$V_{out}(t)$	
--------------	--

Problem 2 (30pts)

Name _____

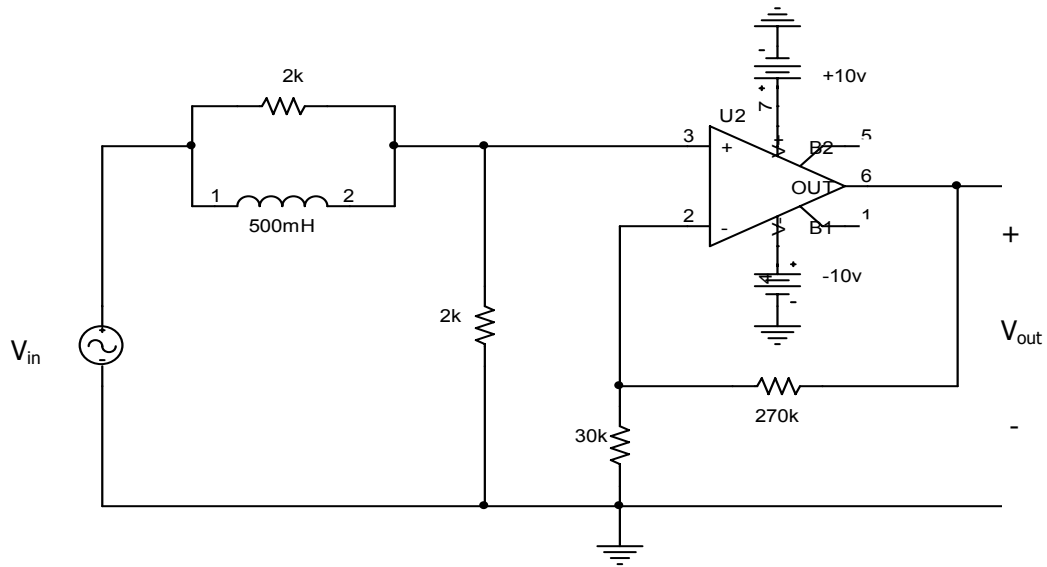

a.) Find $H(s) = \frac{V_{out}(s)}{V_{in}(s)}$ for the above circuit. (10pts)

H (s)	
-------	--

Problem 2 (cont.)

Name _____

b.) Sketch the asymptotic Bode plot $|H(j\omega)|$ and $\Phi H(j\omega)$ for the circuit shown in part (a). Please label your axes and critical values. (10pts)

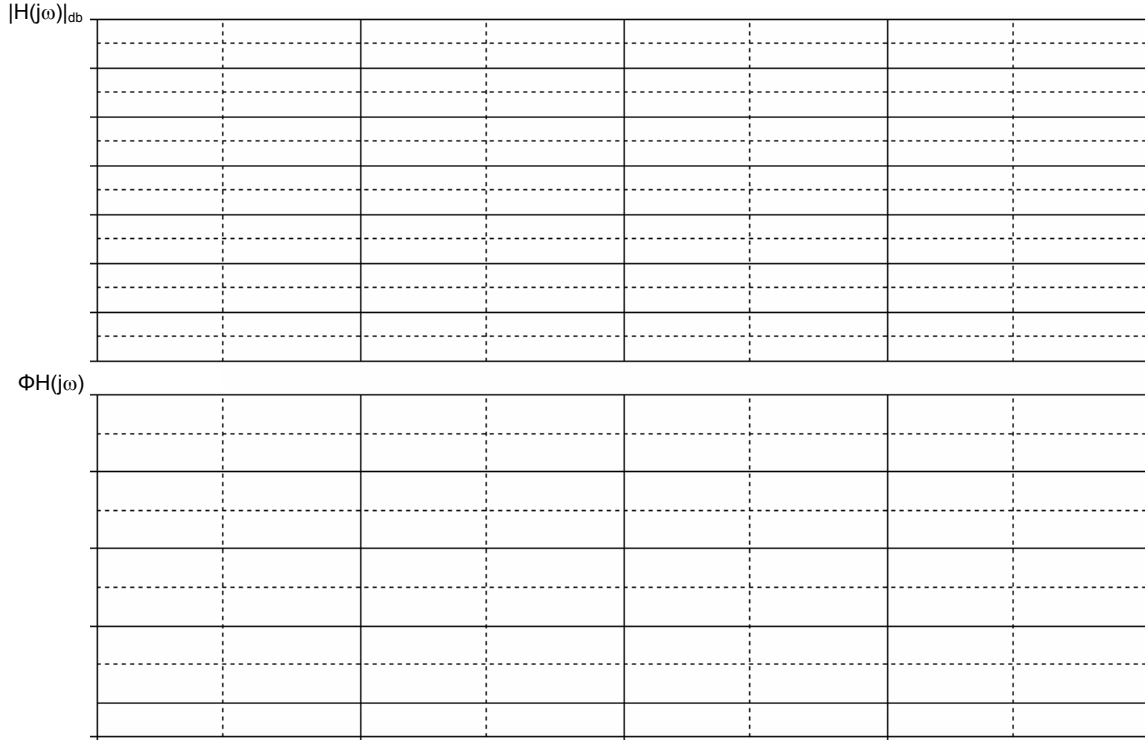

c.) For an input $V_{in}(t) = 5\cos(10t)$, what is the output voltage $V_{out}(t)$? (5pts)

$V_{out}(t)$	
--------------	--

d.) For an input $V_{in}(t) = 5\cos(100kt)$, what is the output voltage $V_{out}(t)$? (5pts)

$V_{out}(t)$	
--------------	--

Problem 3 (10pts)

Name _____

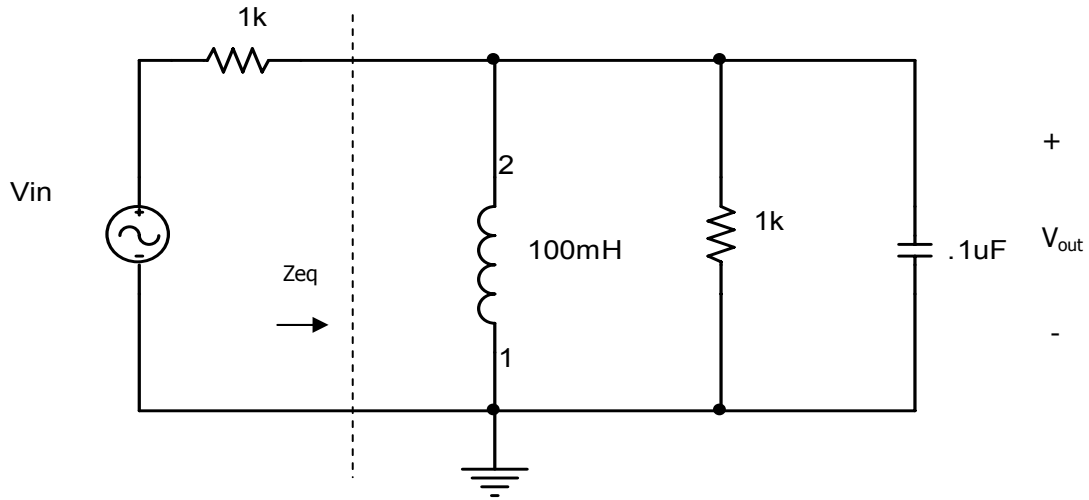

a.) Determine the frequencies (ω , in radians/sec) where Z_{eq} , the equivalent load impedance of the circuit above, is either at a minimum or at a maximum. (6pts)

ω Z_{eq} (min)	
ω Z_{eq} (max)	

b.) What is $V_{out}(t)$ for $V_{in}(t) = 2\cos(\omega_0 t)$, where ω_0 is the resonant frequency? Please justify your response. (4pts)

$V_{out}(t)$	
--------------	--

Problem 4 (20pts)

Name _____

Given the following frequency response:

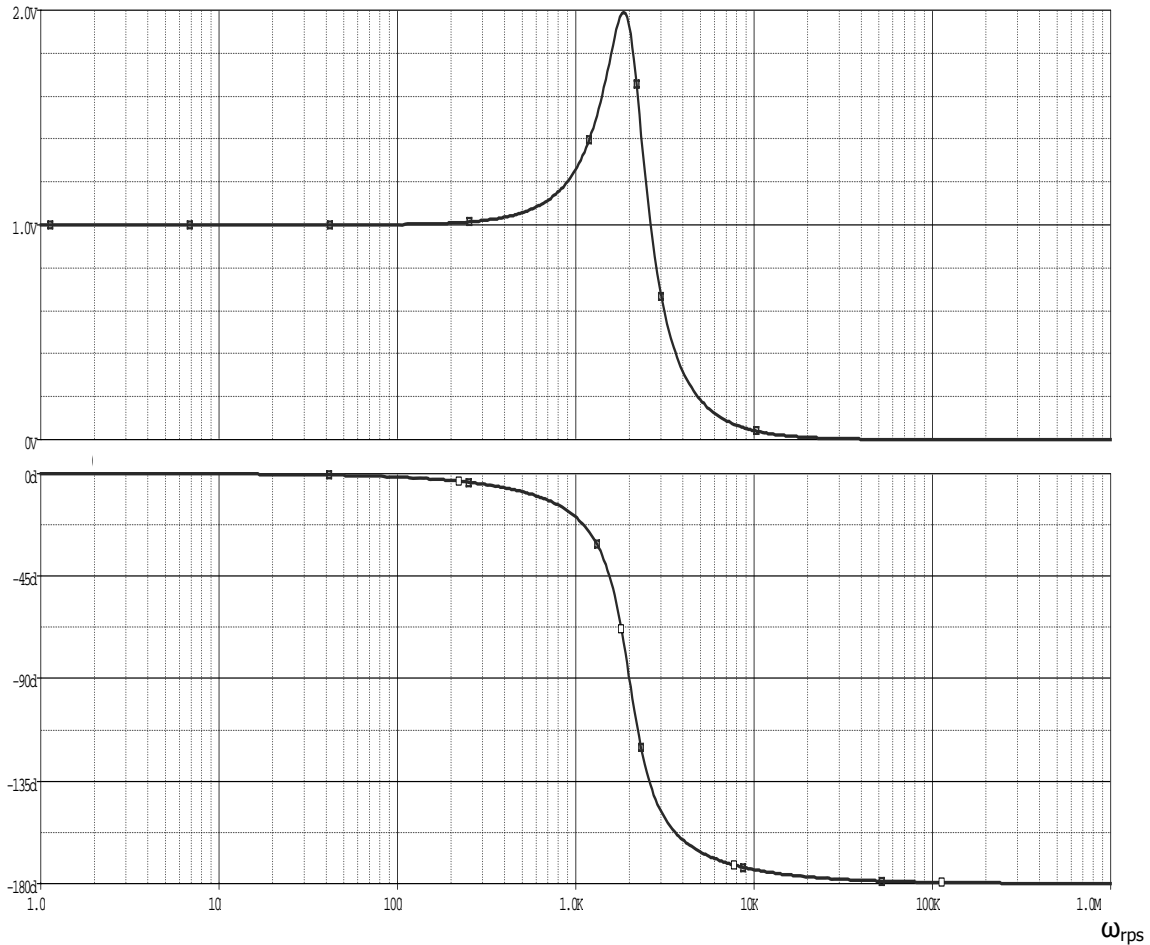

a.) Would this response offer a good circuit for a guitar's tone control? Please circle one and justify your response. (5pts)

Yes	No
-----	----

b.) What kind of filter does this circuit represent? (Circle any/all that may apply and explain your response in the space provided below.) (5pts)

Lowpass	Bandpass	Highpass	Notch
---------	----------	----------	-------

Problem 4 (cont.)

Name _____

c.) Design a circuit that would produce the frequency response shown above, using only one resistor, one inductor and one capacitor. (10pts)

Problem 5 (20pts)

Name _____

a.) Find $H(s) = \frac{V_{out}(s)}{V_{in}(s)}$ for the circuit shown. (5pts)

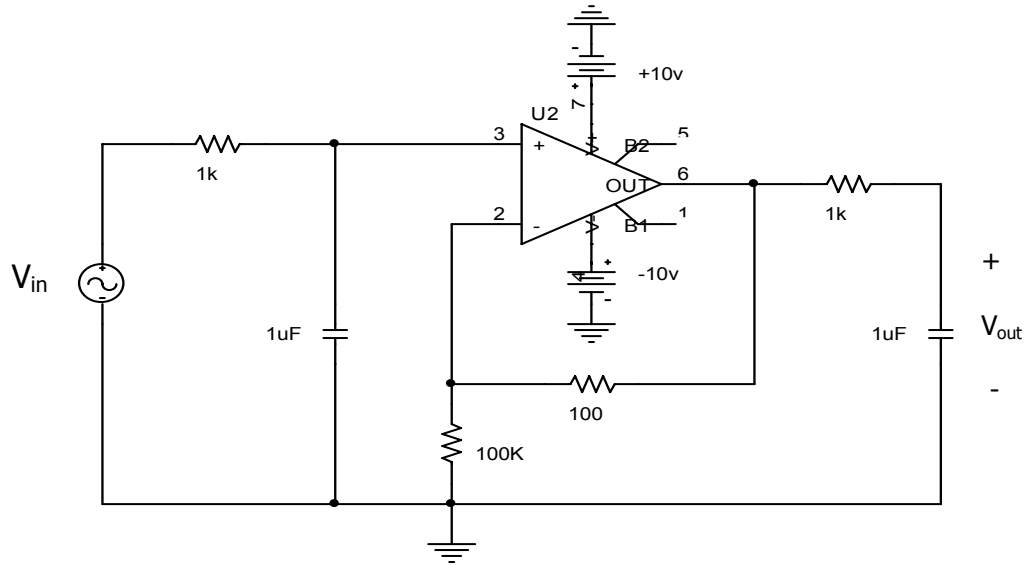

H(s)	
------	--

Problem 5 (cont.)

Name _____

b.) What $V_{out}(t)$ would be produced if $V_{in}(t) = 10\cos(100K_{rps}t+20^\circ)$? Justify your response. (5pts)

$V_{out}(t)$	
--------------	--

c.) What kind of filter could this circuit represent? (Circle one and explain your response in the space provided below.) (5pts)

2 nd order HPF	1 st order LPF	2 nd order BPF	None of these
---------------------------	---------------------------	---------------------------	---------------

d.) Could the same overall frequency response be produced with less components/devices? Please justify your response in the space below to get credit. (5pts)

Yes	No
-----	----

Extra space (if needed)

Name _____

Section Number (please circle one)

1
MTR
10-12

2
MWR
4-6

3
MTR
2-4

Extra space (if needed)

Name _____

Section Number (please circle one)

1
MTR
10-12

2
MWR
4-6

3
MTR
2-4