

Semiconductor Devices and Models II



Instructor: [Michael Shur](#)

E-mail: shurm@rpi.edu Home page: <http://www.ecse.rpi.edu/shur/>

Homework No 1 Solutions

1. In modern short channel silicon MOSFETs, the interface electric field is so large that the electron energy for the electron motion in the direction perpendicular to the silicon-silicon dioxide interface is quantized and energy subbands are formed (see Fig. 1.)

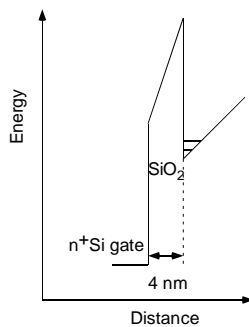

Fig. 1. Energy quantization at Si-SiO₂ interface

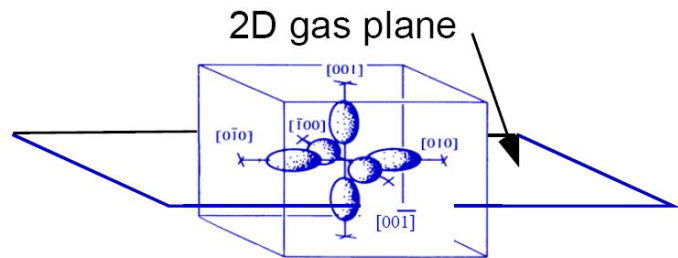

Fig. 2. Surfaces of equal energy in Si.

The subband energies are different for electrons for the two subbands with the heavy electron mass in the direction perpendicular to the silicon-silicon dioxide interface and for electrons for the four subbands with the heavy electron mass in the direction parallel to the silicon-silicon dioxide interface (see Fig. 2.) Hence, two sets of subbands are present with the light and heavy electron mass. Calculate the dependence of the lowest energy subbands for the heavy and light electron effective masses in Si ($m_{\parallel} = 0.916 m_0$; $m_{\perp} = 0.19 m_0$, where $m_0 = 9.11 \times 10^{-31}$ kg is a free electron mass) on the gate voltage. Use the following parameters: dielectric constant of SiO₂ is 3.9; dielectric constant of Si is 11.7, SiO₂ thickness is 4 nm. Also assume that the effective electric field determining the subband energies is equal to $\frac{1}{2}$ of the interface electric field in Si. Assume that the device flat band voltage is equal to zero (see Figure 3) and that the entire gate-to-channel voltage drop is across the silicon dioxide layer.

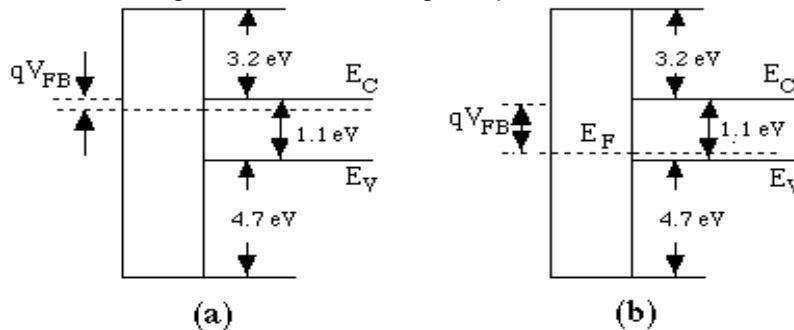

Fig. 3. Band diagrams of silicon MOSFETs with polysilicon gate at flat band. a) MOSFET with *n*-type doping in the bulk (*p*-channel), b) MOSFET with *p*-type doping in the bulk (*n*-channel) (From K. Lee, M. S. Shur, T. Fjeldly, T. Ytterdal, *Semiconductor Device Modeling for VLSI*, Prentice, 1993).

Maximum 25 points

Solution:

First, we calculate the electric field in the oxide*)

$$F_s = V_g/d; (*\text{Field in V/m}*)$$

(*Then we calculate the electric field at the Si-SiO₂ interface*)

$$F_{si} = F_s \epsilon_{SiO_2}/\epsilon_{Si};$$

$$F_{eff} = F_{si}/2;$$

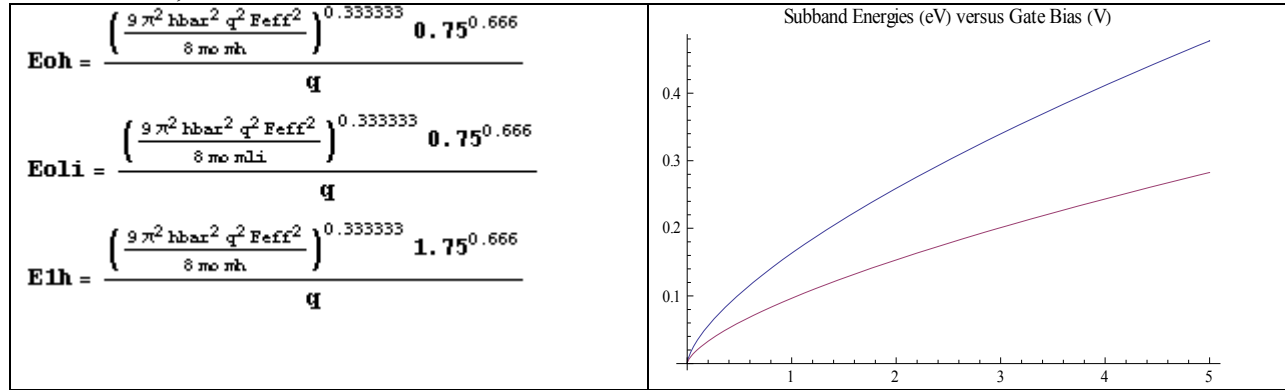

Appendix: silicon band structure

The energy band diagram of silicon is schematically shown in Figure A1.

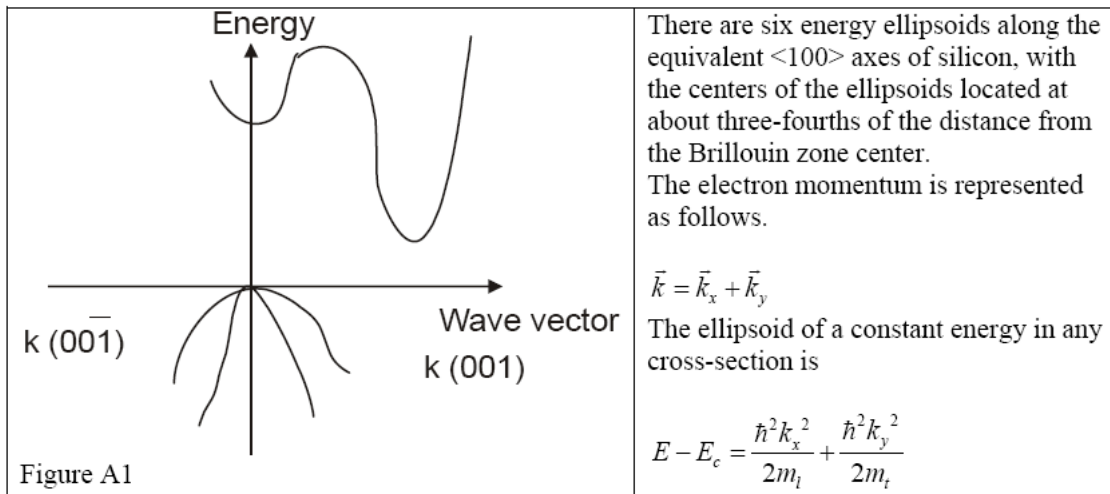

Figure A1

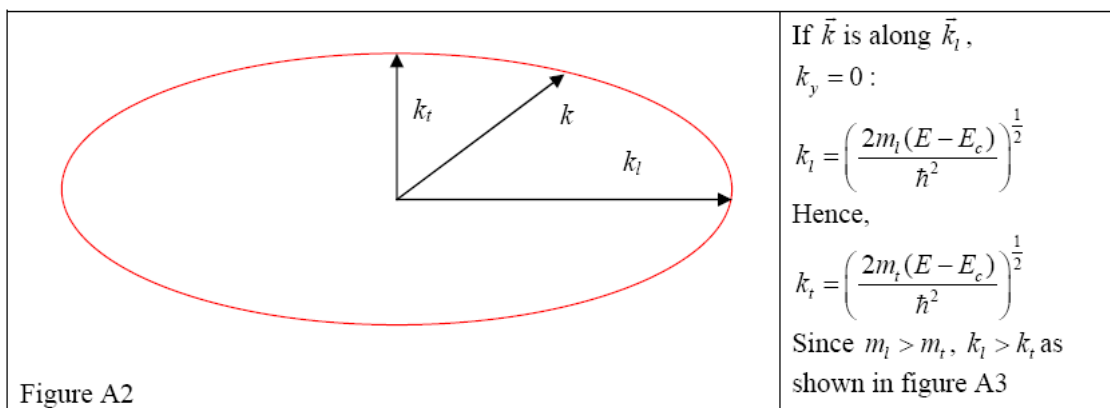

Figure A2

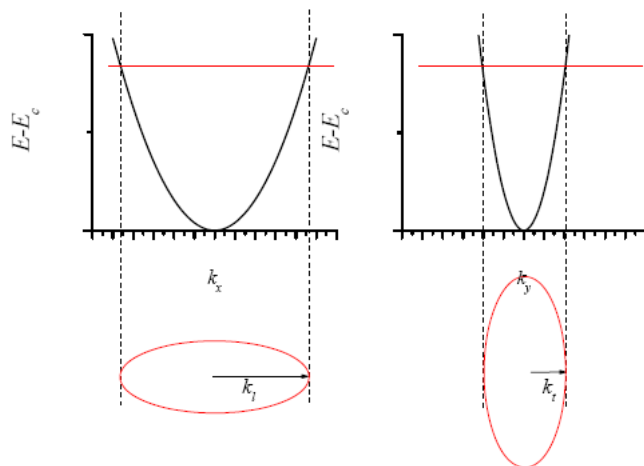

Figure A3

2-3-4. Estimate a GaAs mole fraction, x , in a ternary compound $\text{GaAs}_x\text{Sb}_{1-x}$, such that this compound will be lattice matched to InP.

Hint: Assume a linear variation of the lattice constant with the mole fraction, x , and assume that the lattice constants of InP, GaAs, and GaSb are 5.867 Å, 5.653 Å, and 6.095 Å, respectively.

Solution:

The lattice constant, a , of the ternary compound is given by

$$a = a_{\text{GaAs}}x + a_{\text{GaSb}}(1 - x) \quad (1)$$

Hence, the mole fraction, x , needed to obtain the lattice match to InP, is given by

$$x = \frac{a_{\text{GaSb}} - a_{\text{InP}}}{a_{\text{GaSb}} - a_{\text{GaAs}}} = \frac{6.095 - 5.867}{6.095 - 5.653} = 0.516 \quad (2)$$

4-8-6. Consider a nonlinear element whose I - V characteristic is given by $I = aV^2$, where $V = V_o \sin(\omega_1 t) + V_o \sin(\omega_2 t)$ is the applied voltage. This element is connected in series with a resistor, R_s . Calculate the voltage, V_s , across R_s and show that it contains components with frequencies $\omega_2 - \omega_1$ and $\omega_2 + \omega_1$. (This problem illustrates the operation of a semiconductor mixer.)

Solution:

$$I = a V_o^2 [\sin(\omega_1 t) + \sin(\omega_2 t)]^2 = a V_o^2 [\sin^2(\omega_1 t) + 2 \sin(\omega_1 t) \sin(\omega_2 t) + \sin^2(\omega_2 t)]$$

$$\sin(\omega_1 t) \sin(\omega_2 t) = (1/2) \{ \cos[(\omega_1 - \omega_2)t] - \cos[(\omega_1 + \omega_2)t] \}$$

$$\sin^2(\omega_1 t) = [1 - \cos(2\omega_1 t)]/2$$

$$\sin^2(\omega_2 t) = [1 - \cos(2\omega_2 t)]/2$$

Hence:

$$I R_s = a R_s V_o^2 [1 - \cos(2\omega_1 t)/2 - \cos(2\omega_2 t)/2 + \cos[(\omega_1 - \omega_2)t] - \cos[(\omega_1 + \omega_2)t]]$$

4-9-2. The measured dependence of the resistance between ohmic contacts for the transmission-line-model pattern shown in the figure is shown as a function of the distance between the contacts. The thickness of the doped

n -type layer is $0.1 \mu\text{m}$. The device width is $5 \mu\text{m}$. Assume electron mobility of $1000 \text{ cm}^2/\text{Vs}$. Find the electron concentration in the channel and the contact resistance per mm width assuming the uniform doping level in the channel.

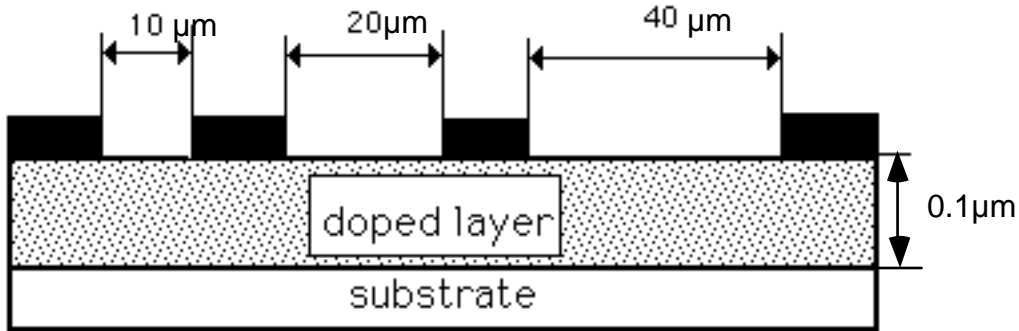

Transmission-line-model pattern. Substrate is undoped.

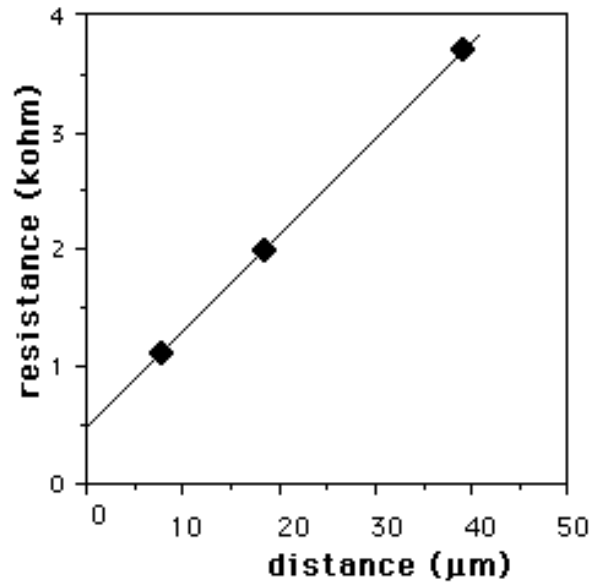

Dependence of the resistance between adjacent ohmic contacts on the distance between the contacts

Solution:

$$R = \frac{R_{ch}L}{W} + 2R_c$$

From the above graph: $2R_c \cong 500 \Omega$ (the intercept). Hence, $R_c \cong 250 \Omega$.

The contact resistance of a 1mm wide device $R_{cm} = R_c(\Omega) \times W(\text{mm}) = 250 \times 5 \times 10^{-3} = 1.25 \Omega\text{mm}$.

$$\text{Slope} \cong \frac{4000 \Omega}{50 \mu\text{m}} \cong 8 \times 10^7 \Omega/\text{m}$$

$$R_{ch} \cong (8 \times 10^7)(5 \times 10^{-6}) \cong 400 \Omega/\text{square}$$

$$R_{ch} = 1/(q\mu N_d t)$$

$$N_d = 1/(q\mu R_{ch} t) = 1/(1.602 \times 10^{-19} \times 0.1 \times 400 \times 10^{-7}) = 1.56 \times 10^{24} \text{ (m}^{-3}\text{)}$$