

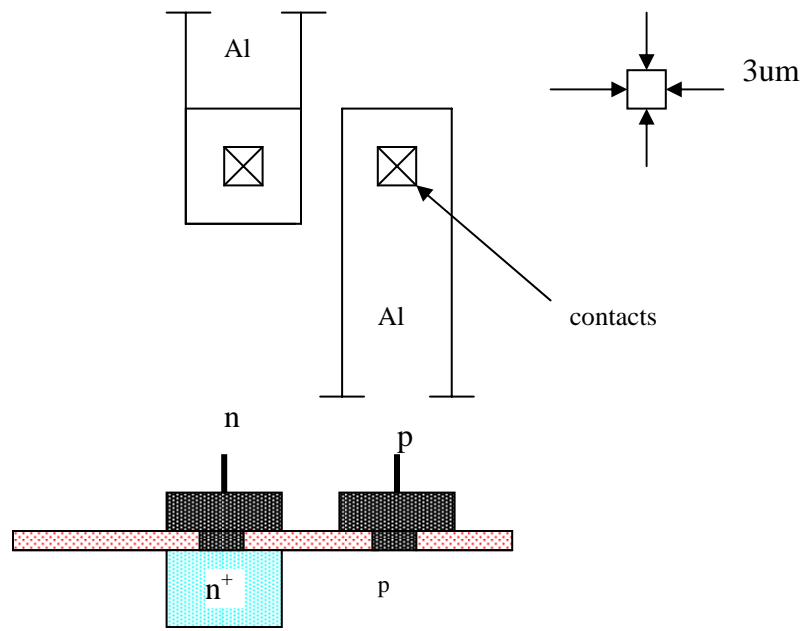

c. What will happen if the contact hole is  $6\ \mu\text{m} \times 6\ \mu\text{m}$  square? Will the device work?





6. The n-well in CMOS should be connected to the **(positive, negative: choose one)** part of the power supply and the p-type substrate should be connected to the **(positive or negative: choose one)** part of the power supply. Explain why.