

Chapter 7. Small-signal admittance

We will study the small signal response of the pn junction diode. A small ac signal (v_a) is superimposed on the dc bias. This results in ac current (i). Then, admittance Y is given by:

$$Y = i / v_a = G + j\omega C$$

Specifically, the following parameters will be studied.

Reverse bias junction or depletion layer capacitance
Forward bias diffusion or charge storage capacitance
Forward and reverse bias conductance.

Capacitance measurements

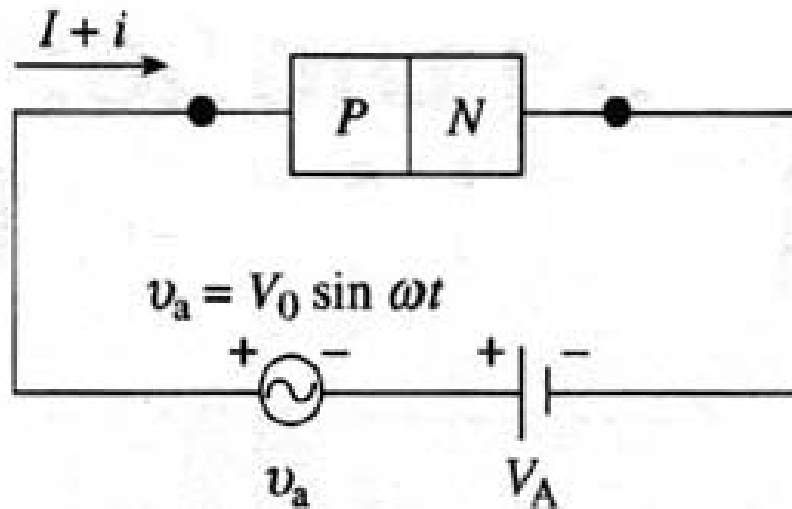

$I = \text{dc}$

$i = \text{ac}$

$Y = \text{admittance}$

$$= \frac{i}{v_{ac}} = G + j\omega C$$

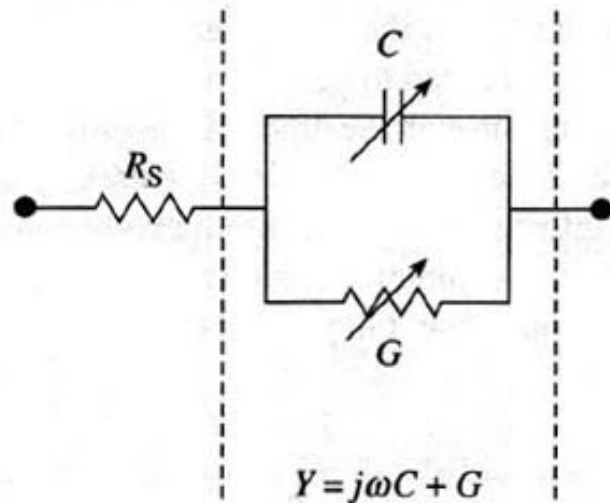

i and v_a depends on the applied dc bias

Model for a diode under ac

Reverse bias junction capacitance

pn junction under reverse bias behaves like a capacitor.

Such capacitors are used in ICs as voltage-controlled capacitors.

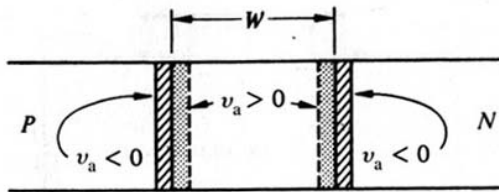

Depletion layer width under small ac superimposed on DC bias voltage.

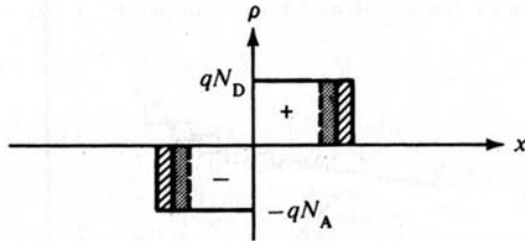

Looks similar to a parallel plate capacitor.

$$C_j = \frac{\epsilon_{Si} A}{W}$$

where W is the depletion layer width under dc bias.

Reverse bias junction capacitance

$$W = \left[\frac{2\epsilon_{\text{Si}}}{q} \left(\frac{N_A + N_D}{N_A N_D} \right) (V_{\text{bi}} - V_A) \right]^{1/2} \quad \text{For pn junction}$$

$$= \left[\frac{2\epsilon_{\text{Si}}}{qN_B} (V_{\text{bi}} - V_A) \right]^{1/2} \quad \text{For p}^+\text{n or pn}^+\text{ junction where } N_B \text{ is the doping on the lightly doped side}$$

$$C_J = \frac{\epsilon A}{W} = A \left(\frac{\epsilon_{\text{Si}} q N_B}{2(V_{\text{bi}} - V_A)} \right)^{1/2} \quad \text{For asymmetrically doped junction}$$

C_J increases with $N_B^{1/2}$

C_J decreases with applied reverse bias

Parameter extraction/profiling

C-V data from a pn junction is routinely used to determine the doping profile on the lightly doped side of the junction.

$$C_J = \frac{\epsilon A}{W} = A \left(\frac{\epsilon_{Si} q N_B}{2(V_{bi} - V_A)} \right)^{1/2}$$

$$\frac{1}{C_J^2} = \frac{2}{A^2 q N_B \epsilon_{Si}} (V_{bi} - V_A)$$

If the doping on the lightly doped side is uniform, a plot of $1/C_J^2$ versus V_A should be a straight line with a slope inversely proportional to N_B and an extrapolated $1/C_J^2 = 0$ intercept equal to V_{bi} .

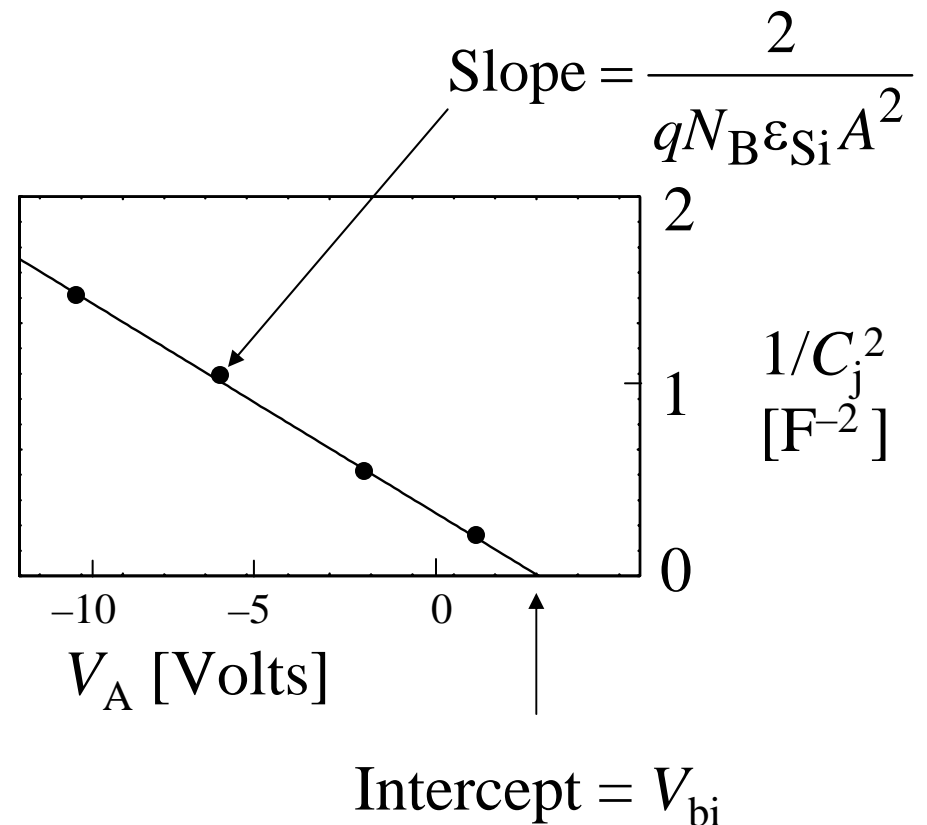

Forward bias diffusion capacitance, C_D

C_D is also called the charge storage capacitance. Minority carrier charge fluctuation results in diffusion capacitance. Both C_J and C_D are always present, but for forward biased case, C_D becomes dominant.

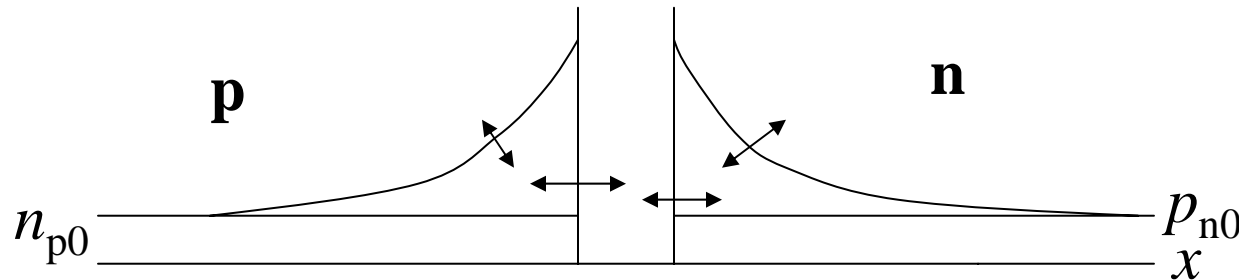

origin of diffusion capacitance.

For a p^+n junction, $I = Q_p/\tau_p$ where Q_p is total excess charge in n-side

$$Q_p = I\tau_p = qA \frac{D_p \tau_p}{L_p} p_{n0} \left[\exp\left(\frac{qV_A}{kT}\right) - 1 \right] \approx qAL_p p_{n0} e^{\frac{qV_A}{kT}}$$

$$C_D = \frac{dQ_p}{dV} = \frac{q}{kT} qAL_p p_{n0} \exp\left(\frac{qV_A}{kT}\right) = \frac{q}{kT} I \tau_p$$

Forward bias conductance

$$G_D = \frac{dI}{dV} = \frac{qAD_p p_{n0}}{L_p} \frac{d}{dV} \left(e^{\frac{qV_A}{kT}} \right) = \frac{q}{kT} I$$

Assumes

$$\omega\tau_p \ll 1$$

Complicated at
higher frequencies.

$$G_D = \frac{q}{kT} I$$

$$C_D = \frac{q}{kT} I \tau_p$$

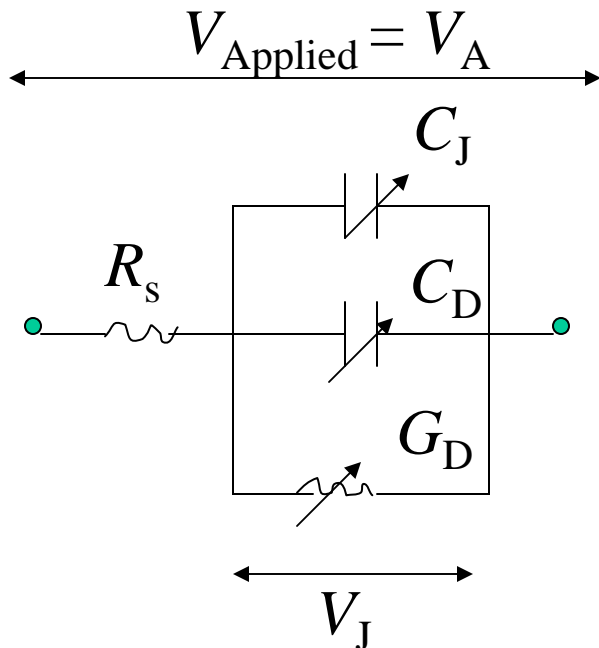

Equivalent circuit for a diode

Example

Consider a p⁺n junction forward biased such that the forward current is 1 mA. Assume the lifetime of holes is 10⁻⁷ s. Calculate the diffusion capacitance and the diffusion resistance.

(Review question) The current through the depletion layer will mostly be carried by (holes, electrons: choose one). Plot the current carried by the holes and electrons through the n-type region, assuming that the diffusion length of holes is 1 μm.

Answer: $C_D = 3.86 \text{ nF}$ $r_d = 1/G_D = 25.9 \text{ Ohms}$