

Class #13: Experiment Phase Shift in Steady-State Circuits

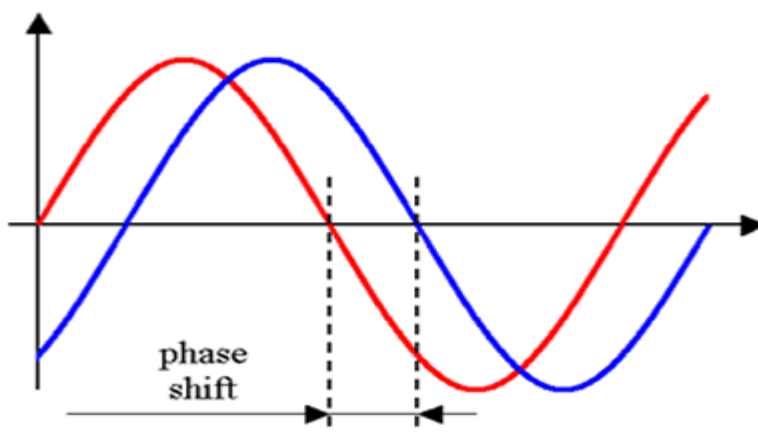

Purpose: The objective of this experiment is to begin to become familiar with and how to handle the phase shift between signals in circuits and engineering in general.

Background: Before doing this experiment, students should be able to

- Analyze simple circuits consisting of combinations of resistors.
- Measure resistance using a Multimeter.
- Do a transient (time dependent) simulation of circuits using LTspice
- Build simple circuits consisting of combinations of resistors, inductors, capacitors, and op-amps on protoboards and measure input and output voltages vs. time.
- Make differential voltage measurements using Analog Discovery and Waveforms.
- Review the background for the previous experiments.

Learning Outcomes: Students will be able to

- Determine and validate mathematical expressions for steady-state sine and cosine voltage and current waves including amplitude, frequency and phase.
- Use the mathematical expressions that describe voltage and current signals obtained both experimentally and using simulation to validate and understand the relationships between voltage and current for inductors and capacitors.

Equipment Required:

- **Analog Discovery** (with Waveforms Software)
- **Oscilloscope** (Analog Discovery)
- **Function Generator** (Analog Discovery)
- **Protoboard**
- Resistors, Capacitors, Diodes, 9V battery and connector
- LTspice

Helpful links for this experiment can be found on the course website under Class #12.

Pre-Lab

Required Reading: Before beginning the lab, at least one team member must read over and be generally acquainted with this document and the other **required reading** materials.

Hand-Drawn Circuit Diagrams: Before beginning the lab, hand-drawn circuit diagrams must be prepared for all circuits either to be analyzed using LTspice or physically built and characterized using Analog Discovery.

Due: At the beginning of Class #15

Part A – RC Circuits in Steady-State

Background

To prepare for the following experiments, review the material in <http://www.electronics-tutorials.ws/accircuits/phase-difference.html>, particularly the information on phase.

Experiment

We begin with a very simple experiment with an RC circuit driven by a 1kHz sinusoidal voltage. Build this circuit on your protoboard using a 1kΩ resistor and a 1μF capacitor. The voltage source shown is provided by the Analog Discovery function generator (AWG1). Connect channel 1 of your Analog Discovery board across the capacitor (to measure the capacitor voltage) and channel 2 across the resistor (to measure the current). Add the ground wire to the bottom of the circuits, for a total of 6 connections to Analog Discovery.

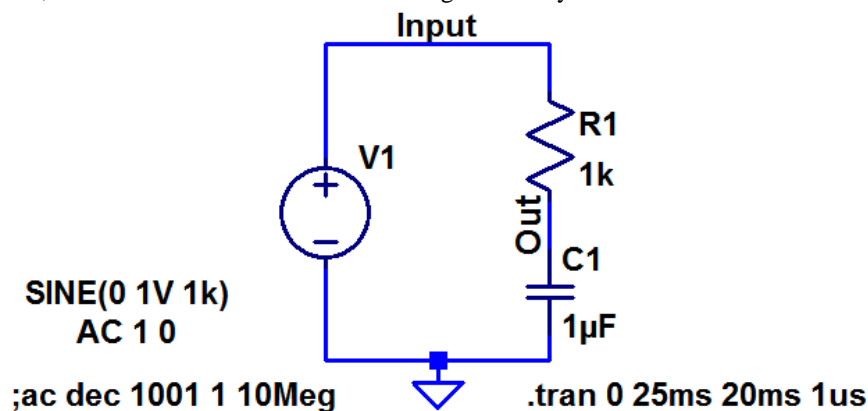

Figure A-1

Before making any measurements, we need to first put things in context by answering a few questions.

1. What type of filter is this circuit? (e.g. high pass, low pass ...)
2. What is the corner frequency for this circuit? Is the 1kHz input signal above, below, near or far from the corner frequency?
3. Is the output voltage likely to be about the same, smaller or much smaller than the input signal, given its frequency?
4. By convention, the phase of the source is defined to be zero. Given its amplitude and frequency, write out the mathematical expression for the source voltage as a function of time. That is, write it out in the form $V(t) = V_o \sin \omega t$. In the actual application, it may be more convenient to use the cosine form of this expression. TA/Instructor _____ (questions 1-4)

Open the Analog Discovery Oscilloscope. Set the horizontal scale to show five full periods of the 1kHz signal. Remember that there are ten divisions in both the horizontal and vertical directions on the scope display, which should tell you how much time you need per division. For the vertical scales (each channel can have its own vertical scale), we would like to have the measured voltage use as much of the vertical scale as possible. Set up the function generator to produce the 1V, 1kHz sine wave. Note that you have done an experiment similar to this before, but may not have set up the measurements quite the same way.

Start both the function generator and the scope and make any additional adjustments to optimize your display. Using the cursors, determine the time between identical features on the two signals. Choose easy to identify features. See, for example, the figure at the beginning of this document. You can also choose the peaks or troughs. Save the plot to your report and annotate it (amplitude, frequency, period, time between features). Also export your data so you can read it in Excel.

5. Using the information in your plot, determine the phase shift between the two signals. Express your answer in both radians and degrees.



Return to the experiment and create a new channel from channel 2 and display the current in the resistor (which is also the current in the capacitor). Again, set the vertical scale to use the real estate available in the display as fully as possible. Find the amplitude, frequency, periods and time between features for the capacitor voltage and current, using the same steps as above. Save the plot to your report and fully annotate it. Export your data so you can read it in Excel.

6. Using the information in your plot, determine the phase shift between the two signals. Express your answer in both radians and degrees. Is it the same as in question 5?
7. Now write mathematical expressions for your voltage and current in the forms $V(t) = V_o \sin \omega t$ and $I(t) = I_o \sin(\omega t + \mathcal{G})$, respectively. Note that you are free to write them using a cosine form if it is more convenient. TA/Instructor _____

To check your experimental results, before analyzing them in Part B, simulate the same experiment using LTspice. All of the information necessary to set up the circuit and simulation is shown in Figure A-1. Do the transient simulation not the AC sweep. The latter is not active, as indicated by the semi-colon. If the simulation does not agree exactly with your experiment, the most likely issue is uncertainty in the values of the capacitor and resistor. Measure the actual value of the resistor and do the simulation with this value. If it still does not agree, try a slightly larger or smaller value for C. Capacitors values are only accurate to $\pm 10\%$. Get the best accuracy you can and then save the plot to your report and annotate it.

8. What values for R and C give the best agreement between experiment and simulation?

Summary

When there are resistors, capacitors and inductors in a circuit, there will be differences between both the magnitude and relative phases of voltages at the input and output of circuits. There will also be a phase difference between voltage and current.

Part B – Validation of the Relationship Between Current and Voltage for a Capacitor

As noted in a previous experiment, if you review the Wikipedia entry for capacitors (<https://en.wikipedia.org/wiki/Capacitor>), you will find that the relationship between current and voltage should be

$$I_c(t) = C \frac{dV_c(t)}{dt}$$

We would like to use the information you have obtained through experiment and simulation to verify this expression. To do this, we will use Excel.

Experiment

Open the data you obtained experimentally in Excel. You should have three columns: time, capacitor voltage and current. Create two more columns using your expressions for voltage and current found in question 7 above. Check the agreement between your mathematical expressions and measured data by plotting both columns for voltage and then both columns for current. If they do not agree, you can adjust the values for amplitude and phase until agreement is good. This should give you better accuracy than the numbers you got from eyeballing your plots.

9. Update the mathematical expressions for voltage and current using your improved parameters. Then evaluate the derivative of your voltage expression. Note that this is a normal mathematical operation, not something to be done with Excel.
10. Verify that $I_c(t) = C \frac{dV_c(t)}{dt}$ using your result for the derivative of voltage. TA/Instructor _____

A similar validation process can be used for inductors, for which $V_L(t) = L \frac{dI_L(t)}{dt}$.

Summary



We have now verified that $I_C(t) = C \frac{dV_C(t)}{dt}$ and $V_L(t) = L \frac{dI_L(t)}{dt}$ work for both transient and steady-state (i.e. sinusoidal) voltages and currents. We are now ready to learn to analyze RC and RL circuits analytically.

Part C – Task Checklist

The following list summarizes the tasks from Parts A and B

- Use general knowledge of filters to predict very roughly how the RC circuit to be built will work.
- Express the source voltage mathematically.
- Use Analog Discovery to plot the input and output voltages for an RC circuit. Plot, annotate and approximately determine key parameters like amplitude and phase shift.
- Use Analog Discovery to plot the current and voltage for capacitor in series with resistor. Plot, annotate and approximately determine key parameters like amplitude and phase shift.
- Simulate your RC experiment using LTspice to verify values for R and C.
- Import measured data for capacitor current and voltage into Excel and plot.
- Find mathematical expressions that characterize the voltage and current in a capacitor.
- Compare with measured data using Excel
- Verify the current-voltage relationship for a capacitor, using the expressions for $V(t)$ and $I(t)$